

DATA SHEET

DOOR DETECTOR 03.G5.UPF.169.1800

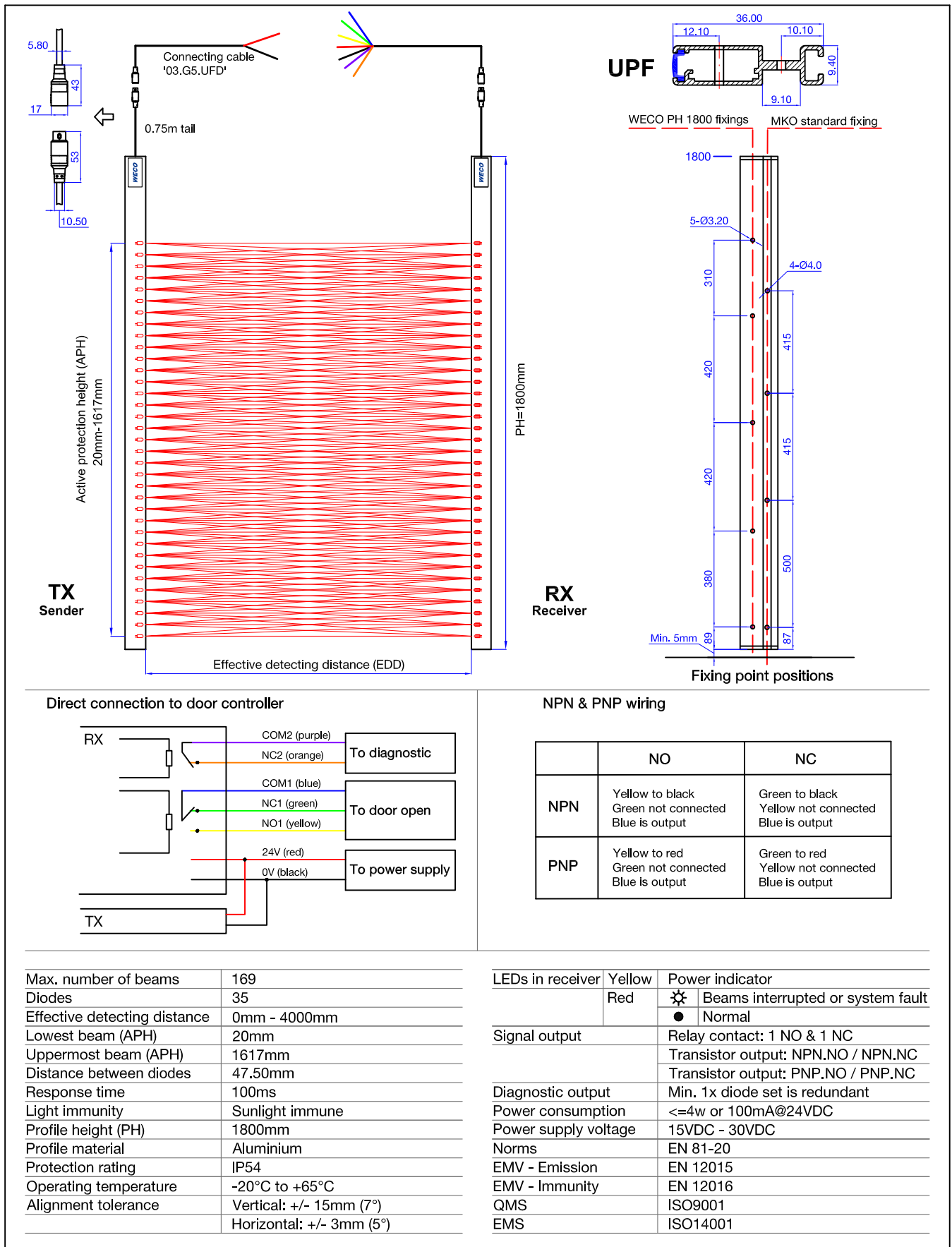

Direct connection to door controller

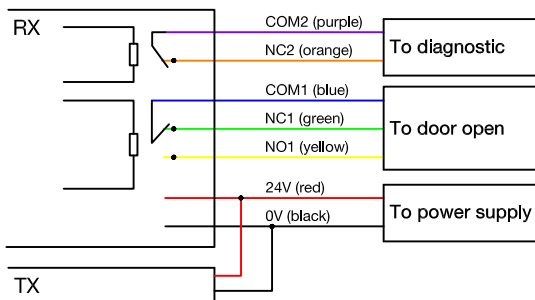

NPN & PNP wiring

	NO	NC
NPN	Yellow to black Green not connected Blue is output	Green to black Yellow not connected Blue is output
PNP	Yellow to red Green not connected Blue is output	Green to red Yellow not connected Blue is output

Max. number of beams	169
Diodes	35
Effective detecting distance	0mm - 4000mm
Lowest beam (APH)	20mm
Uppermost beam (APH)	1617mm
Distance between diodes	47.50mm
Response time	100ms
Light immunity	Sunlight immune
Profile height (PH)	1800mm
Profile material	Aluminium
Protection rating	IP54
Operating temperature	-20°C to +65°C
Alignment tolerance	Vertical: +/- 15mm (7°) Horizontal: +/- 3mm (5°)

LEDs in receiver	Yellow	Power indicator
	Red	Beams interrupted or system fault Normal
Signal output	Relay contact: 1 NO & 1 NC Transistor output: NPN.NO / NPN.NC Transistor output: PNP.NO / PNP.NC	
Diagnostic output	Min. 1x diode set is redundant	
Power consumption	<=4w or 100mA@24VDC	
Power supply voltage	15VDC - 30VDC	
Norms	EN 81-20	
EMV - Emission	EN 12015	
EMV - Immunity	EN 12016	
QMS	ISO9001	
EMS	ISO14001	