

ELECTRICAL DIAGRAM

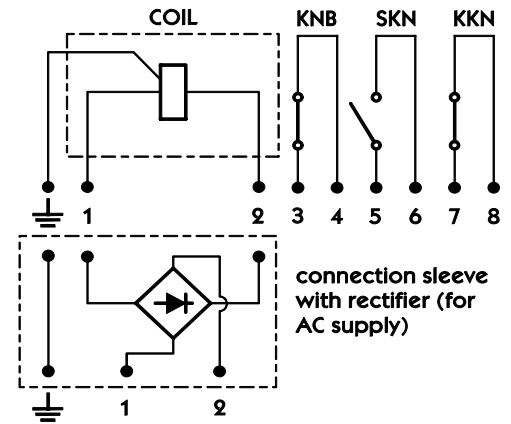

Maximum static load	7000 daN
Maximum stroke (ND)	100 mm
Weight	39 kg
Coil power	50 W
Rated current	0,25 A
Direct current power supply	100, 180 Vdc
Alternate current power supply	230 Vac